

OSCILLATING GRANULATOR

Dry Granulation, Wet Granulation,
Screening, Crushing, Breaking



Fully Designed from German Technology

CE

TAPASYA

PROCESS WITHOUT METAL CONTACT

Granulation : Granulation is a Mechanical process in which the product is pressed through a sieve with a specially shaped rotor-arm to obtain a desired particle size. This process results in a narrow distribution spectrum as only the product having the right shape, size and position, is broken and passed through the sieve.

Oscillating Rotor : The oscillating motion of the rotor improves the granulating process. This sensitive handling of the product emulates the hand operation of an experienced pharmacist.

One important feature of the oscillating granulator is the continuous variation of the speed and force applied to the material. The back and forth motion of the rotor results in an even distribution of the material.

- ! Complete stainless steel. All parts in contact with the product in AISI 316/316L.
- ! Inside polished Ra = 0.8 micron, outside ground (grain 220)
- ! Maintenance free design, GMP execution.

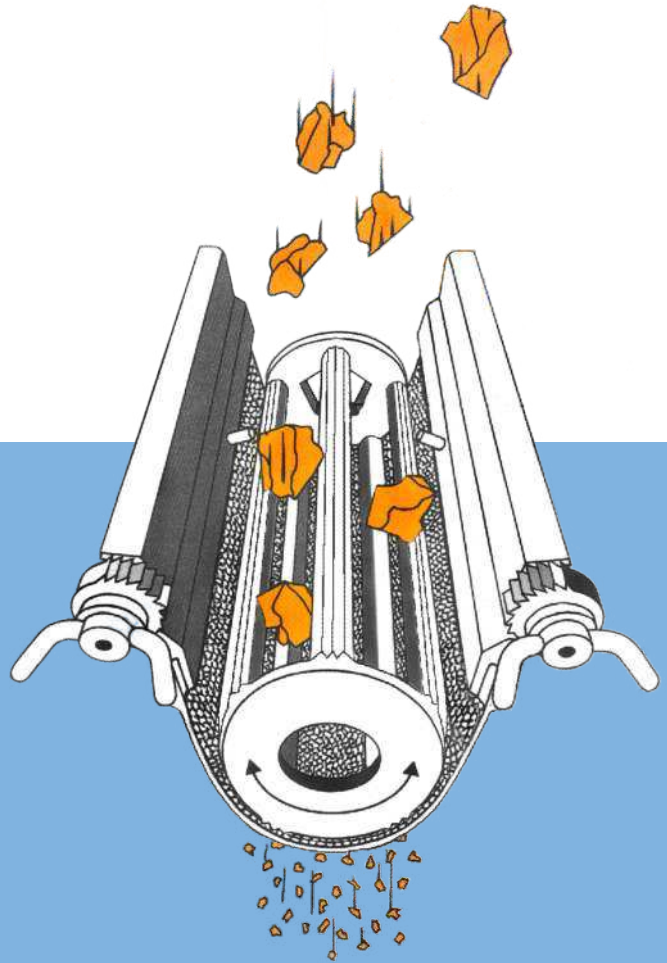

SIEVE / PERFORATED PLATE :

Tapasya offers a variety of sieves available in the market today. It includes fine sieves and perforated plates to meet the most demanding customer requirements.

- Range: 0.5 mm to 10 mm

SALIENT FEATURES

- ! Robust, Simple & Compact Design
- ! Stainless Steel Construction
- ! Easy Installation in Production Line
- ! Oscillating Rotor Motion
- ! High Output
- ! Uniform Granules, Less Fines
- ! Low noise level as per international norms
- ! Maintenance Free
- ! Easy for Cleaning

OSCILLATING GRANULATOR

Dry Granulation, Wet Granulation, Screening, Crushing, Breaking

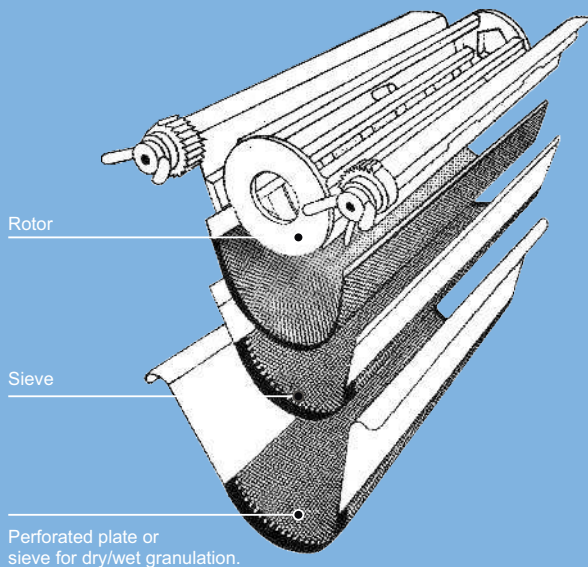

TECHNICAL SPECIFICATION

Output	Upto 400 kg/hr (depending on product & Sieve)
Motor	2HP 1440 RPM 3 Phase, coupled with helical gear unit
Oscillating Speed	180 OPM / variable on request
Power	1.5 KW
Weight	250 Kg. (without stand) 300kg. (with stand)

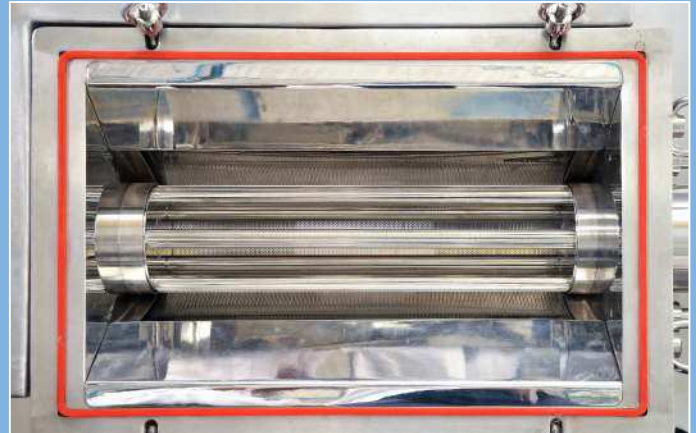
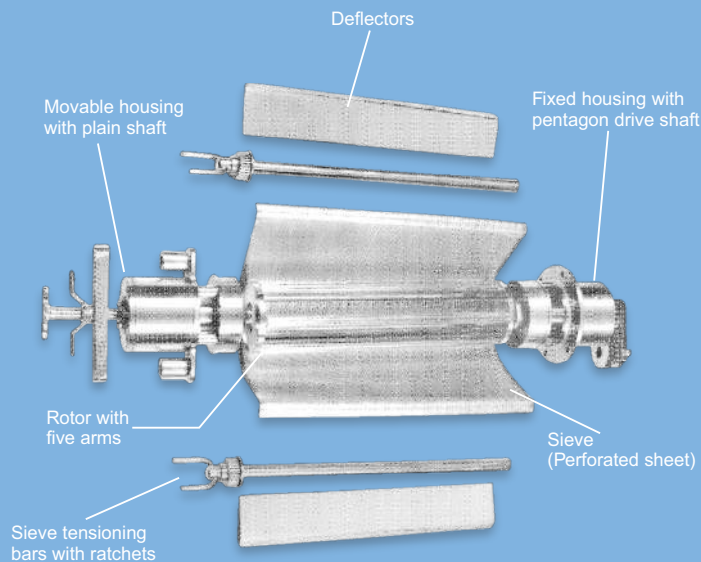

Specification and technical data are subject to without prior notice



Manufactured & Exported By:

Tapasya Engineering Works Pvt. Ltd.

A/212, Road No.30, Wagle Industrial Estate, Thane (W) – 400 604. India

Tel.: +91 - 22- 6157 9400 / 2582 3250 • Fax : +91 - 22- 2582 5243

E-mail: sales@tapasyaindia.net • info@tapasyaindia.net • Web : www.tapasyaindia.net

Our Representatives in USA:

Daiichi Jitsugyo (America), Inc.

939 AEC Drive, Wood Dale, IL 60191

Phone : 630-776-2459 • Email: Rnelson@djausa.com

Web : www.dja-pharma.com • www.tapasyaglobalusa.com

